

KBS Metal Roofing

KBS-100 SNAP-LOCK PANEL & 5V PANEL INSTALLATION MANUAL

Metal Roofing

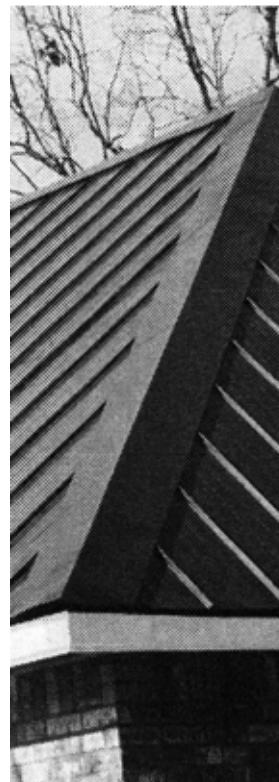

KBS Metal Roofing

General Information

Before beginning installation of panels, the installer should examine the substrate or framing to ensure that all supporting members are straight, level, and plumb to avoid any panel distortion. All substructures should be designed to meet all necessary code requirements.

The installer should thoroughly familiarize himself with all installation instructions before starting work.

This manual contains suggestions and guidelines on how to install Snap-Lock panels. The installation details shown are proven methods of construction, but are not intended to cover all instances, building requirements, designs or codes. It is the responsibility of the designer/installer to ensure that the details meet particular building requirements. The designer/installer must be aware of, and allow for, expansion/contraction of roof panels. The details may require changes or revisions due to each project's conditions.

The panels should be installed plumb, straight, and accurately to the adjacent work. Some field cutting and fitting of panels and trim is to be expected by the installer and minor field corrections are a part of normal installation work.

Installation procedures and penetrations by fasteners in the panel system shall be in accordance with the panel manufacturer's printed instructions, details or the approved shop drawings. Trim shall be installed true, and in proper alignment, with any exposed fasteners equally spaced for the best appearance.

Closures shall not be attached unless the proper sealant is placed under or around these closures. Sealants shall be field applied on dry, clean surfaces.

All trims, closures, and accessories shown on the installation drawings can be provided by KBS Metal Roofing unless noted otherwise.

Oil canning in the flat area of the panels is common to the industry and shall not be a cause for panel rejection.

KBS Metal Roofing

TABLE OF CONTENTS

Product Data Sheet	1
Color/Section Properties	2
Trim Guide (Exposed Fastened)	3-4
Trim Guide (Common for Exposed Fastened)	5
Trim Guide Architectural	6-7
Accessories	8
Handling, Material & Safety Points	9
Minimum Recommended Tools & Equipment	10
Roof Preparation	11
Panel Installation	12-14
Typical Conditions Details and Trims	15
Eave Trim Details	
a. Exposed Fastener.....	16
b. Architectural.....	23
Rake Trim Details	
a. Exposed Fastener.....	17
b. Architectural.....	24
Hip and Ridge Details	
a. Exposed Fastener.....	18
b. Architectural.....	25
Valley Trim Details	
a. Exposed Fastener.....	19
b. Architectural.....	26
High-Side Trim Details	
a. Exposed Fastener.....	20
b. Architectural.....	27
Rake Tie-In Details	
a. Exposed Fastener.....	21
b. Architectural.....	28
High-Side Tie-In Details	
a. Exposed Fastener.....	22
b. Architectural.....	29
Vent Trim Details	30

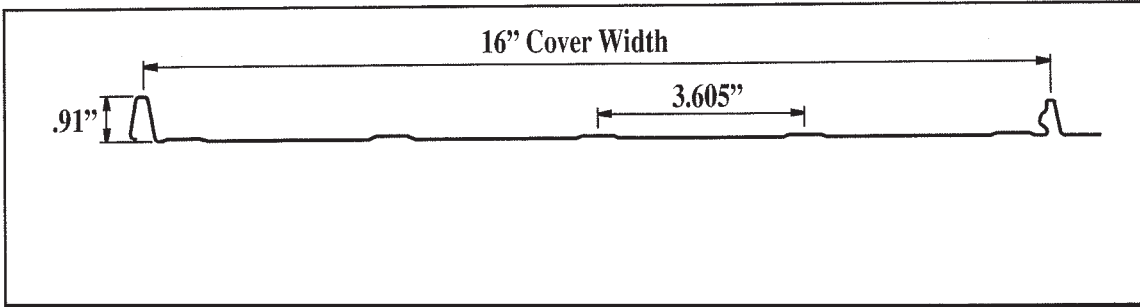

Snap-Lock is an economical, snap-together, concealed fastener roofing panel. Snap-Lock is ideal for residential and commercial applications. Panels are simply installed by placing pancake head fasteners in the panel's slotted flange. Snap-Lock should be installed over solid decking.

PANEL OPTIONS

Panel Width: 16"

Panel Configurations:
16" Ribbed

Standard Panel Length: Up to 40'
Please inquire for longer lengths.

Minimum Slope: 3:12

Substrate: Galvalume®

Paint System: Kynar 500®

Gauge: 24 and 26

Oil canning is a natural occurrence in metal panels and is not a cause for panel rejection.

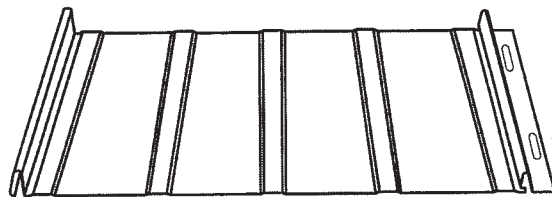
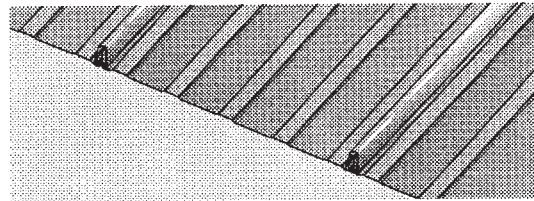

16" panel with ribs

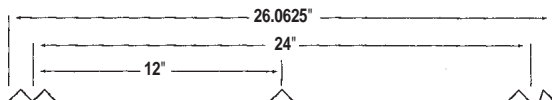

5V Panel

TESTING

Class A - Fire Rating
ASTM E 1680 - Air Infiltration
ASTM E 1646 - Water Infiltration
UL 2218 - Class 4 Impact Resistance

SECTION PROPERTIES

Panel Gauge	Weight PSF	FY KSI	TOP IN COMPRESSION			BOTTOM IN COMPRESSION		
			Ix IN.4	Se IN.3	Ma KIP IN.	Ix IN.4	Se IN.3	Ma KIP IN.
26	0.92	50	.0086	.0101	.3012	.0052	.0082	.2464
24	1.20	50	.0113	.0131	.3907	.0075	.0112	.3347

1. Section properties and allowables are computed in accordance with the 1986 edition of the AISI specifications.
2. Ix is for deflection determination.
3. Se is for bending.
4. Ma is the allowable bending moment.
5. All values are for one foot of panel width.

KBS Metal Roofing

SECTION PROPERTIES

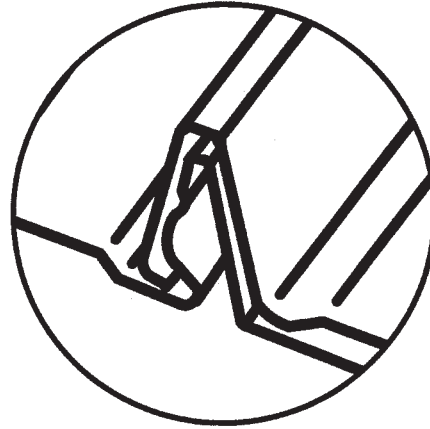
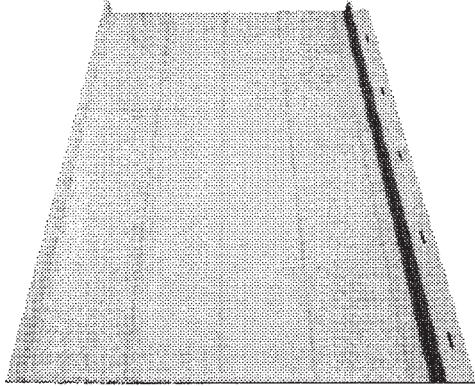

GAUGE	COATING	WIDTH
26 GA.	KYNAR 500®	16"
26 GA.	Galvalume Plus®	16"

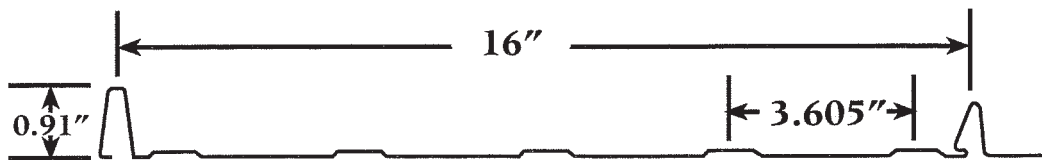
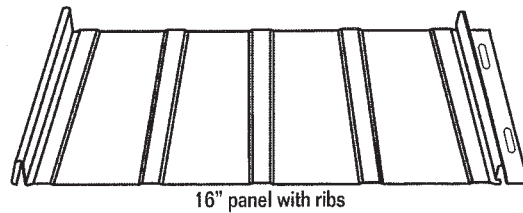

SECTION PROPERTIES FOR 16" PANEL

PANEL GAUGE	WEIGHT PSF	FY KSI	TOP IN COMPRESSION			BOTTOM IN COMPRESSION		
			I _x IN ⁴	S _e IN ³	M _a KIP IN	I _x IN ⁴	S _e IN ³	M _a KIP IN
26	0.92	50	.00864	.01006	.3012	.00516	.00823	.2464
24	1.20	50	.01125	.01305	.3907	.00754	.01118	.3347

NOTES:

1. Section properties and allowables are computed in accordance with the 1986 edition of the AISI specifications.
2. I_x is for deflection determination.
3. S_e is for bending.
4. M_a is allowable bending moment.
5. All values are for one foot of panel width.

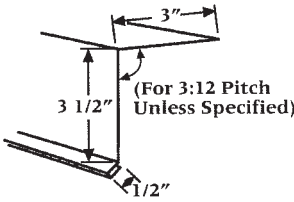
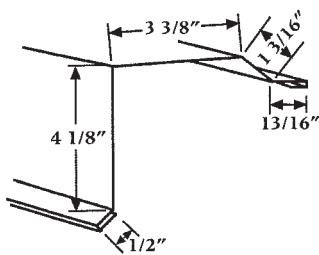
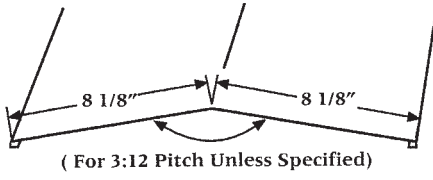
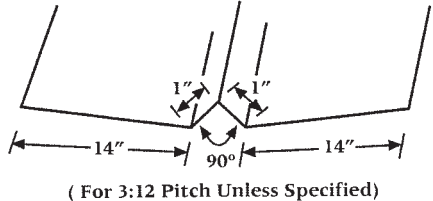
Description	PROFILE	LENGTH
Eave Trim		Specify Roof Pitch 10'-3" 20'-3"
Rake Trim		10'-3" 20'-3"
Ridge Trim		Specify Roof Pitch 10'-3" 20'-3"
Valley Trim		Specify Roof Pitch 10'-3" 20'-3"

KBS Metal Roofing

TRIM GUIDE (EXPOSED FASTENER)

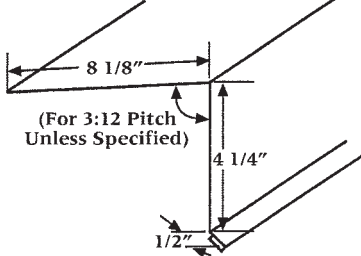
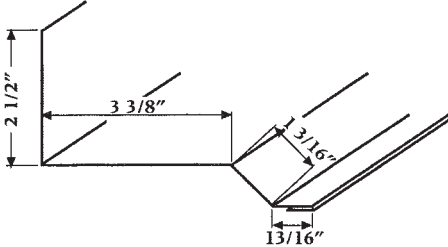
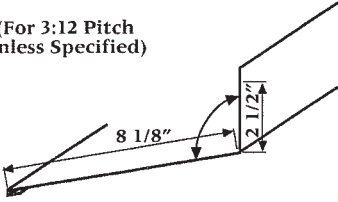
Description	PROFILE	LENGTH
High Side Trim	 <p>(For 3:12 Pitch Unless Specified)</p>	Specify Roof Pitch 10'-3" 20'-3"
Rake Tie-In		10'-3" 20'-3"
Highside Tie-In	 <p>(For 3:12 Pitch Unless Specified)</p>	Specify Roof Pitch 10'-3" 20'-3"

KBS Metal Roofing

TRIM GUIDE (COMMON FOR EXPOSED FASTENER & ARCHITECTURAL)

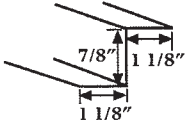
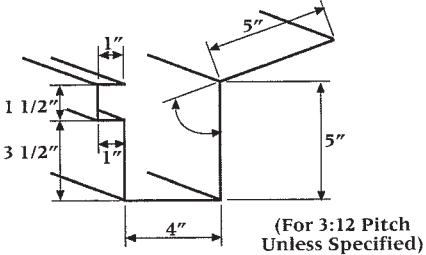
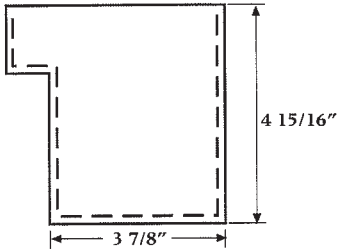
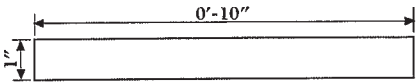
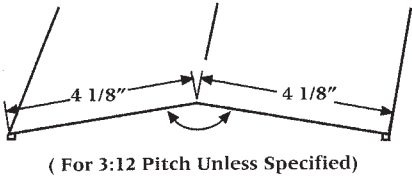
Description	PROFILE	LENGTH
Zee Closure		10'-3"
Gutter		Specify Roof Pitch 10'-3" 20'-3"
Gutter End Cap		
Gutter Strap		
Hip Trim		Specify Roof Pitch 10'-3" 20'-3"

KBS Metal Roofing



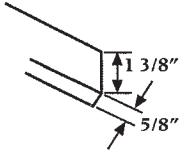
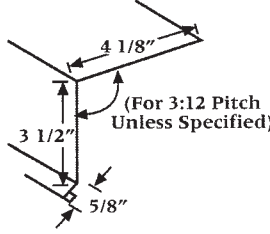
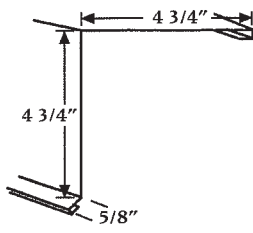
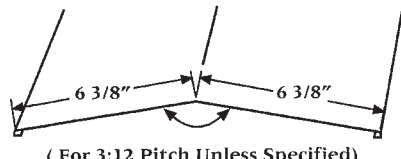









TRIM GUIDE (ARCHITECTURAL)

Description	PROFILE	LENGTH
Perimeter Cleat		10'-3"
Eave Trim		Specify Roof Pitch 10'-3" 20'-3"
Rake Trim		10'-3" 20'-3"
Ridge Trim		Specify Roof Pitch 10'-3" 20'-3"

Description	PROFILE	LENGTH
Valley Trim		Specify Roof Pitch 10'-3" 20'-3"
High Side Trim		Specify Roof Pitch 10'-3" 20'-3"
Highside Tie-In Trim		Specify Roof Pitch 10'-3" 20'-3"
Rake Tie-In Trim		10'-3" 20'-3"
Eave Drip Trim		Specify Roof Pitch 10'-3" 20'-3"
Offset Cleat		10'-3"

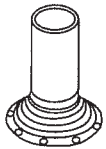
KBS Metal Roofing

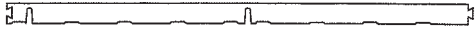
ACCESSORIES

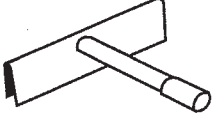
PROFILE	DESCRIPTION
	#14 x 7/8" Lap Tek Zac
	#10 x 1" W/O Washer - Plain Socket - 1/4"
	#10 x 1" Zac With Washer - Plain Socket - 1/4"
	#10 x 1" Pancake Head Phillips Plain - Wood Screw 1" x 3/8"
	Butyl Tube Sealant 511
	White Urethane Sealant
	Roll Tape Sealant 3/32" x 1" (8 Bead) x 45' Roll
	Pop Rivet Stainless Steel w/Stainless Mandrel - 1/8" STST43D
	Dektite Dektite Flashing Roof or Wall Pipe #1 Fits 1/2" - 2"OD Pipe #3 Fits 1/4" - 4"OD Pipe #5 Fits 4" - 7"OD Pipe #7 Fits 6" - 11"OD Pipe #8 Fits 7" - 13"OD Pipe Other sizes available upon request
	Inside Closure Plug
	Outside Closure
	Touch - Up Paint
	Hemming Tool

Handling

Check shipment for damage or missing quantities immediately. Notify Customer Service if there is any damage or missing pieces.

Panels must be stored in a dry, well ventilated area. To keep condensation to a minimum, make sure panels are elevated at one end for runoff from any condensation that may occur. Do not store panels in direct contact with the ground.

Panel bundles less than 25 feet may be unloaded with a forklift. Forks should be at least five feet apart, and panels picked up at the bundles center of gravity. Panel bundles longer than 25 feet in length must be lifted using a spreader bar.

Galvalume® coated panels can be discolored or damaged by handling. Installer should: 1) wear clean gloves when handling panels; 2) wear soft, non-marking, soled shoes when walking on panels.

Safety Points

Do not walk on panel seams. Walk only in the flat areas of the panels.

Wear proper clothing and safety attire.

Do not handle panels on extremely windy days. Panels can become lifting objects and can lift individuals off of roof or panels can become airborne.

Metal panels can be slippery when wet or dusty. Do not work on a metal roof when these conditions persist. Soft soled shoes will help minimize slipping and reduce damage to panel finish.

Be aware of surroundings: i.e. overhead electrical wires, roof pitch, roof edges or openings and any other possible obstructions.

KBS Metal Roofing

MINIMUM RECOMMENDED TOOLS AND EQUIPMENT

Electric Screw Gun
Snips
Tape Measure
Electric Metal Shear*
Caulk Gun
Electric Drill
Pop Rivet Tool
Chalk line
"Duckbill" Locking Pliers
Eave Turn Down Tool

*We do not recommend the use of a power circular saw. Use of a power saw could:

- 1) increase the instance of edge rust; 2) increase metal particles on a panel surface which could damage panel finish.

Installer must have prior experience and knowledge of the listed tools and their uses in working with metal roofing.

Roof Preparation

Snap-Lock is an excellent choice for residential or light commercial applications. There are several topics that the installer needs to address before installing Snap-Lock.

On New Construction:

- Snap-Lock is designed to be installed over solid decking.
- Make sure the roof is clear of any debris that might interfere with installation.
- KBS Metal Roofing recommends that the installer uses no less than a 30 lb. felt underlayment and highly recommends Titanium underlayment.
- Installer needs to utilize an alignment or “chalk” line where the first panel is installed. KBS recommends that this line be vertical and 1/4" from the rake edge of the roof deck and square with the eave. Other methods of confirming the modularity (or squareness) can also be used.

On Existing Roofing:

- Snap-Lock is designed to be installed over solid decking.
- Make sure any existing decking is smooth, level and in good condition. Replace any decking not meeting those requirements.
- If there is an existing asphalt shingle roof, check local building codes to determine whether existing shingles must be removed.
- If installing over existing shingles, KBS Metal Roofing recommends the use of horizontal “furring” strips and foam insulation placed between furring strips. This will insure a solid and level substrate to attach panels.
- Make sure the roof is clear of any debris that might interfere with installation.
- KBS recommends that the installer uses no less than a 30 lb. felt underlayment and highly recommends Titanium underlayment.

Fastener Spacing

Maximum Fastener Spacing* For 16" wide 26 GA. panels with wind loads to 80 mph.

<u>Deck Thickness</u>	<u>Spacing</u>
1/2"	18" o.c.
5/8"	21" o.c.
3/4"	24" o.c.

Slot on leg may not coincide with above chart.

KBS Metal Roofing

PANEL INSTALLATION

To Begin:

*Note: See #8 before you begin installation. Panels can be terminated at the eave in two different configurations. If you choose the smooth configuration #8 on page 14, panels should be field cut prior to being installed on the roof.

1. Align the female edge of the first panel with the chalk line that was snapped at the rake edge. Remember, this line can be 0"- 1 3/4" from the rake. Panel should overhang eave 1". See Figure #1.

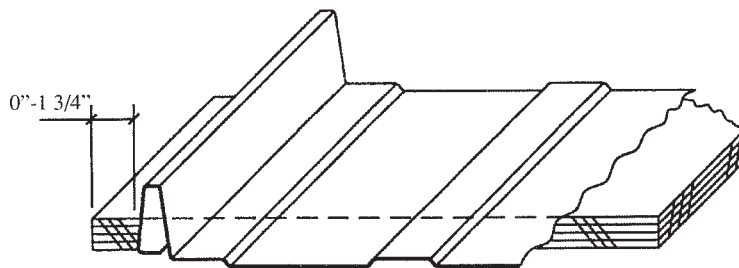

Figure #1

2. At ridge: Panels should be installed perpendicular to ridge for ridge trim attachment.
3. Check panel alignment. If panel is properly aligned, attach rake edge to roof with a #10x1" Woodgrip . (See Figure #2) Then fasten the panel along the male edge fastening flange. See previous table on page 11 for fastener spacing.

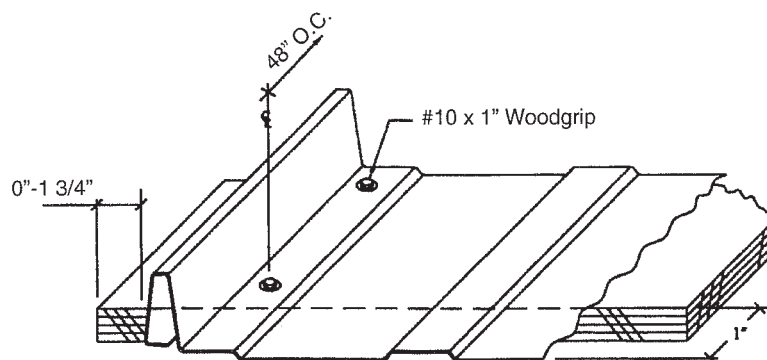
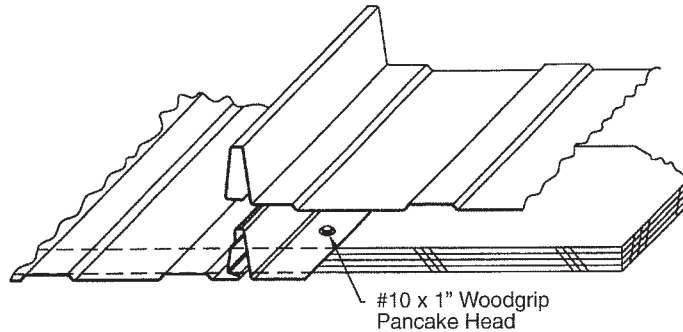

Figure #2

4. Align the second panel female edge with the starter panel male edge. See Figure #3. Panels must be flush at eave edge. Remember, panels should extend over eave by 1".

Figure #3



5. Lightly compress and snap panels together at seam. Snap panels from eave to ridge.
6. After panel seam is locked, fasten the panel with a #10x1" Pancake Woodgrip Plain along the male leg. Follow the recommended fastener spacing as per the chart on page 10.
7. Continue to apply panels as in steps #4 thru #6 above.
8. Panels at the eave can be terminated in two ways. Each will depend on aesthetic considerations determined by the installer or building owner.
 - a. Panels can be fastened along the eave with a #10x1" painted fastener. Fasten along a line parallel to the eave edge and 3" up from the eave edge. The fasteners can be spaced as shown below in Figure #4. Maximum panel run (length) 30'-0" using exposed fasten eave condition.

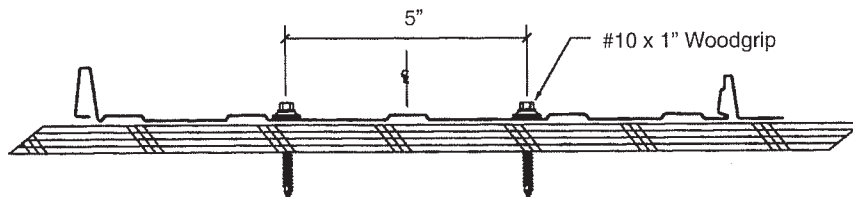

Figure #4

KBS Metal Roofing

PANEL INSTALLATION

- b. Panels can also be terminated with a hemming tool to provide a smoother appearance. Cut through male and female legs/ribs 1 1/2" up from panel end as shown in Figure #5.

FIGURE #5

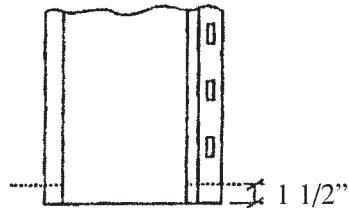

Then cut diagonally with metal shears as shown in Figure #6.

FIGURE #6

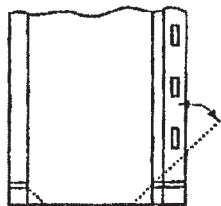

Place hemming tool over panel tab. Bend down and under to 180° as shown in Figures #7 & #8.

FIGURE #7

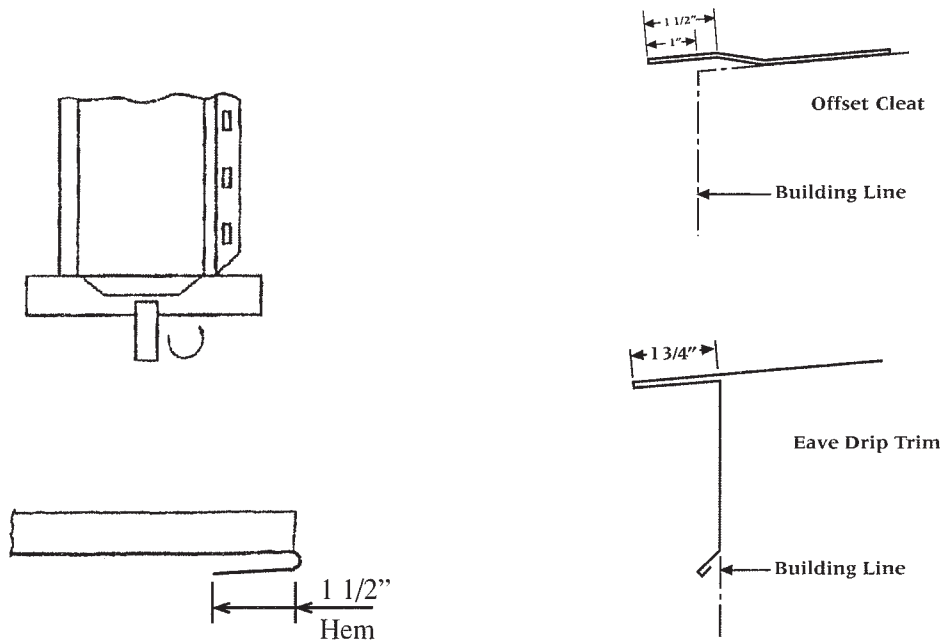

Note: When the eave drip trim condition is used, the panel lengths need to be 3/4" longer than panels used for offset cleat condition.

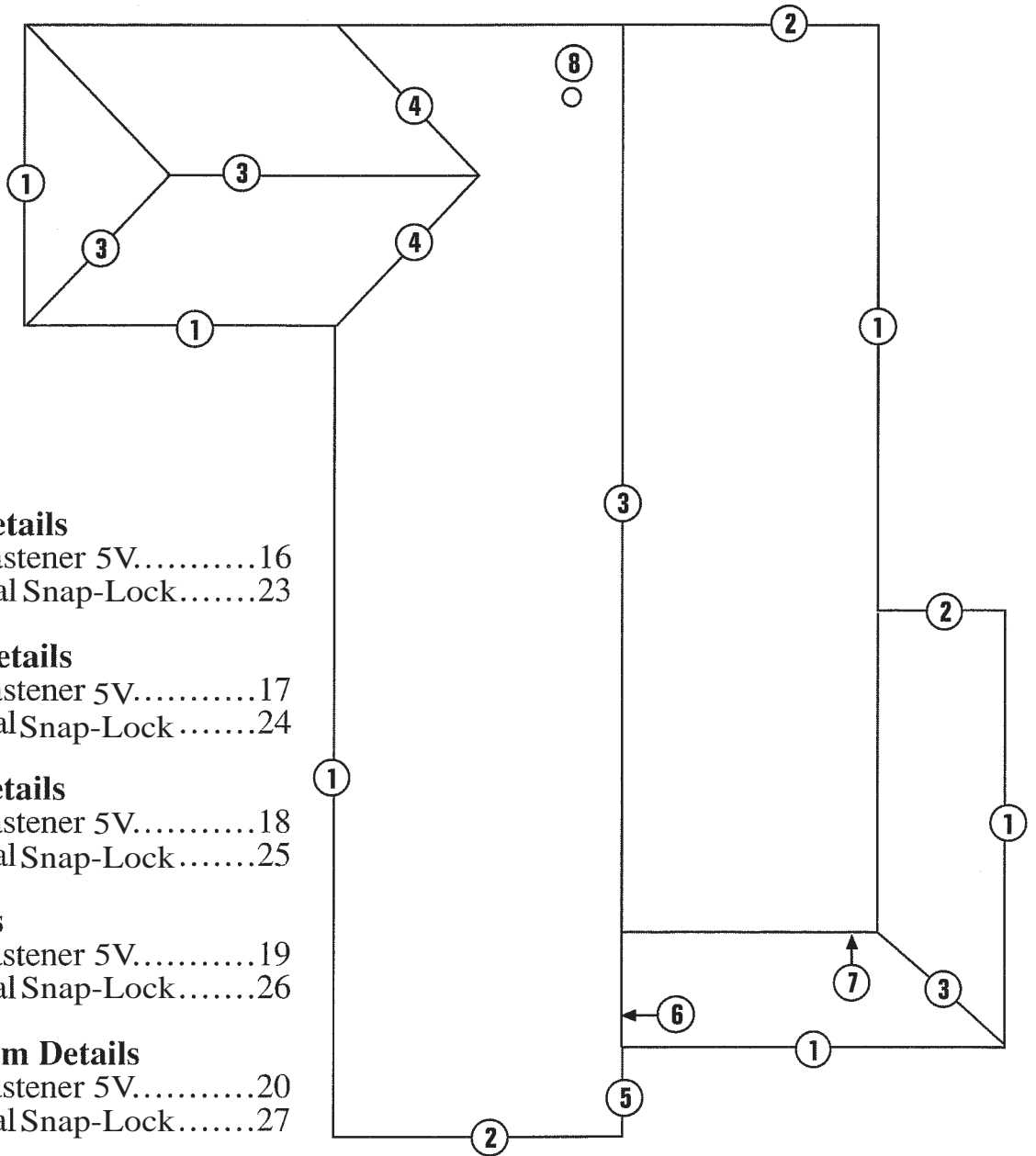

1. **Eave Trim Details**
 - A. Exposed Fastener 5V.....16
 - B. Architectural Snap-Lock.....23
2. **Rake Trim Details**
 - A. Exposed Fastener 5V.....17
 - B. Architectural Snap-Lock.....24
3. **Ridge/Hip Details**
 - A. Exposed Fastener 5V.....18
 - B. Architectural Snap-Lock.....25
4. **Valley Details**
 - A. Exposed Fastener 5V.....19
 - B. Architectural Snap-Lock.....26
5. **High Side Trim Details**
 - A. Exposed Fastener 5V.....20
 - B. Architectural Snap-Lock.....27
6. **Rake Tie-In Details**
 - A. Exposed Fastener 5V.....21
 - B. Architectural Snap-Lock.....28
7. **High Side Tie-In Details**
 - A. Exposed Fastener 5V.....22
 - B. Architectural Snap-Lock.....29
8. **Vent Trim Details.....30**

KBS Metal Roofing

TYPICAL CONDITIONS

Eave Trim Details - Exposed Fastened

Note: Eave trim must be installed prior to panel installation.
Also, panel should overhang the eave 1" minimum.

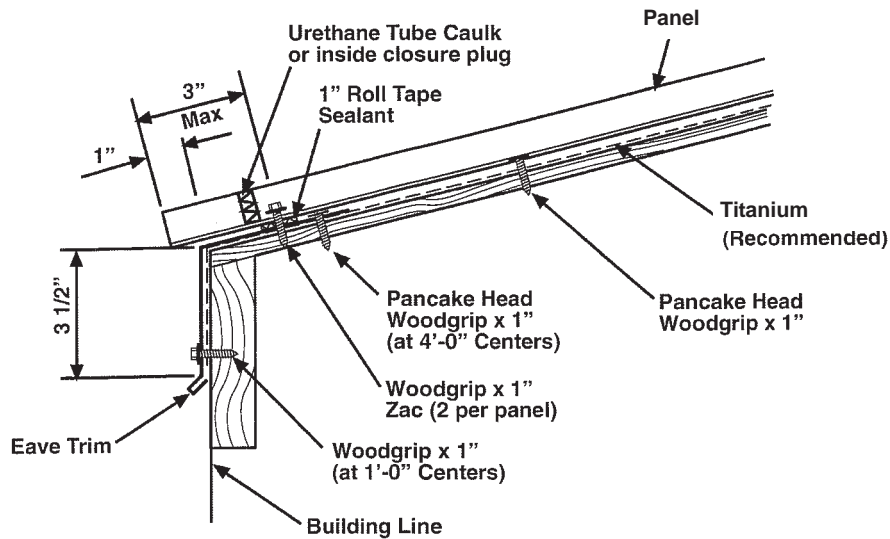
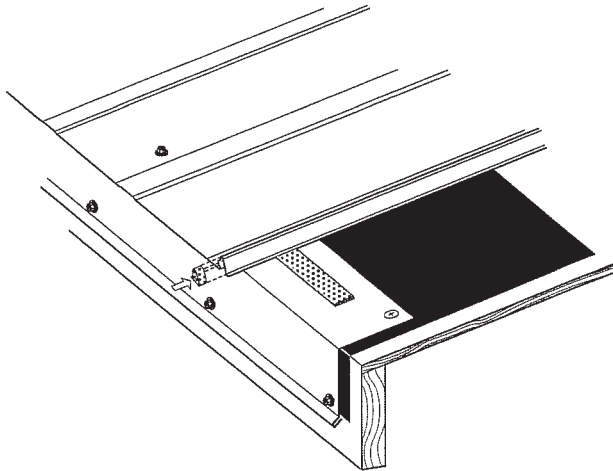
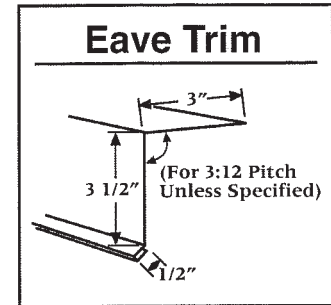

1. Attach eave trim as shown with #10x1" Pancake Woodgrip fastener.
2. Open the hem of the next trim for approximately 4".
3. Caulk and lap the trim a minimum of 3" hooking the hem.
4. Install panel and fasten at eave with #10 x 1 Woodgrip Zac.

** Additional ice and water shields may be required if climate is extreme.

Rake Trim Details - Exposed Fastened

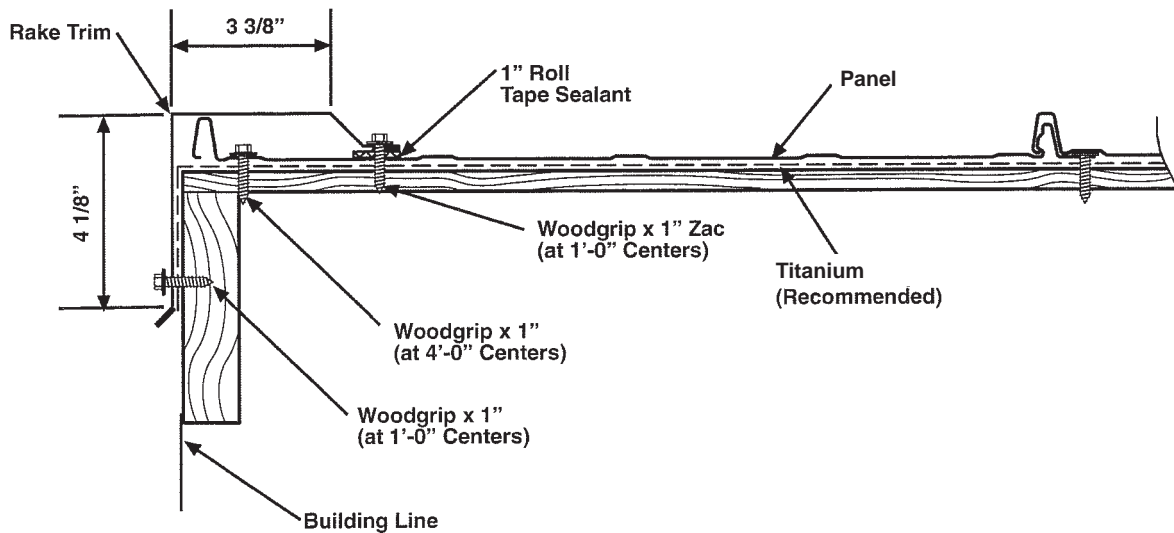
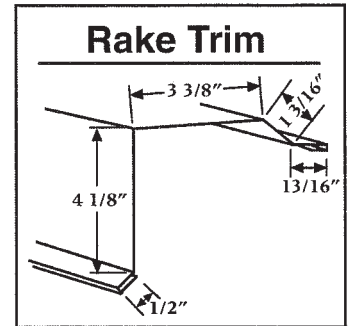
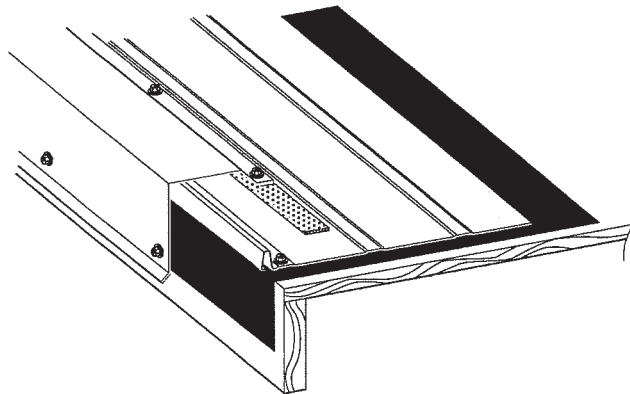

1. Make sure that roof panel is placed as per instructions on page 12.
2. Place tape sealant along the rake trim's flange.
3. Install rake trim over rib. Fasten using painted #10x1 Woodgrip at 12" o.c.
4. Caulk and lap the rake trim at least 3" hooking the hem.
5. Miter cut the rake trim at the peak to join each side at the ridge.
6. Cut and fold the rake at the eave to seal the end. Use painted STST 43D pop rivets to fasten.
7. End rake trim detail is the same as outlined in #1-6.

KBS Metal Roofing

TYPICAL CONDITIONS

Hip & Ridge Trim Details - Exposed Fastened

Note: Rake trim must be installed prior to installing the ridge. Panels must be field cut at hip.

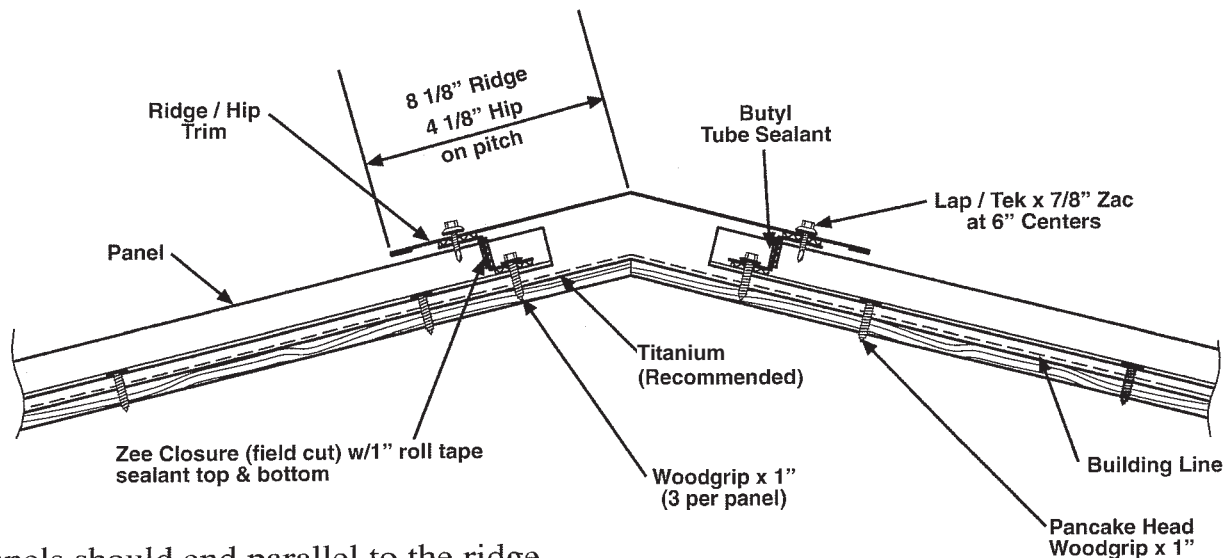
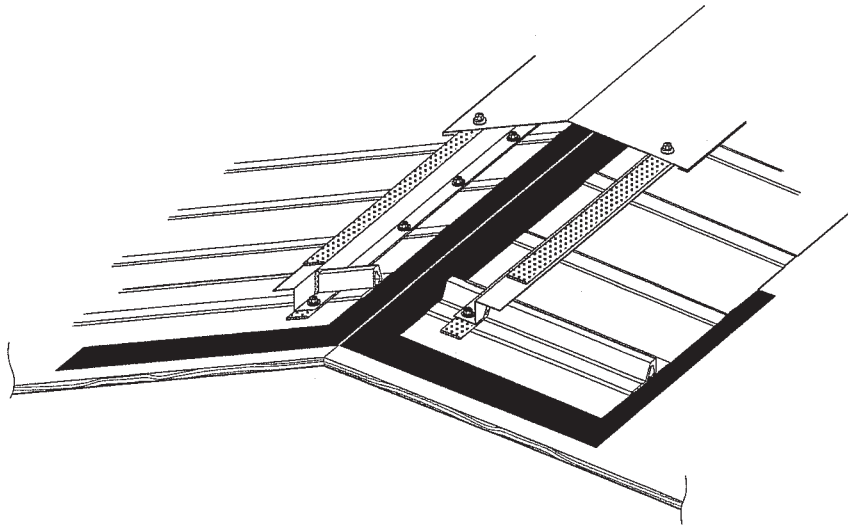
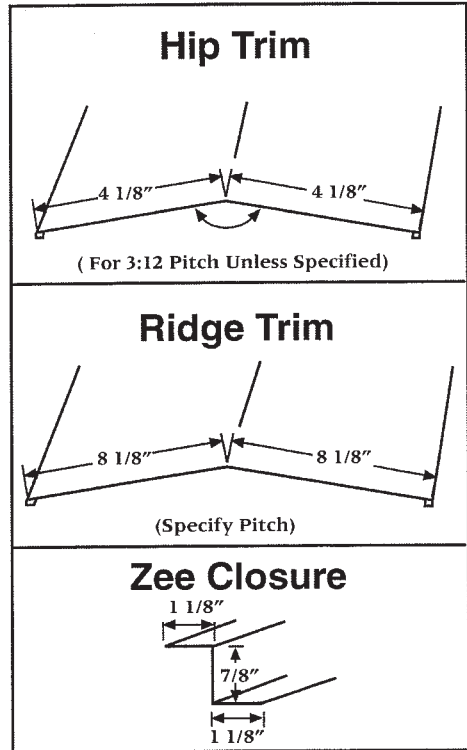

1. Panels should end parallel to the ridge.
2. Attach zee closure parallel to ridge.
3. Fasten hip/ridge trim to the zee using #14 x 7/8" Lap / Tek Zac.
4. Caulk, lap and fasten the subsequent trims.

Valley Trim Details - Exposed Fastened

Note: Valley trim must be installed prior to panel installation. Panels must be field cut.

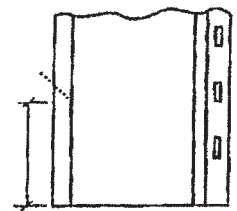
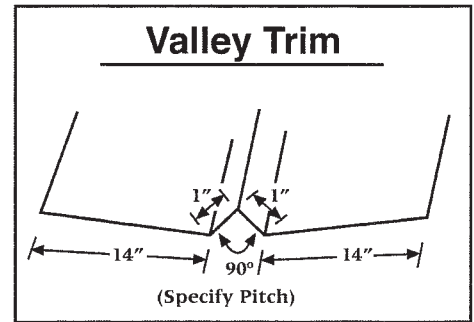

Figure #9

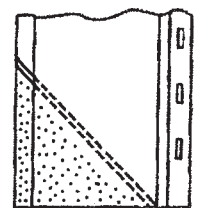
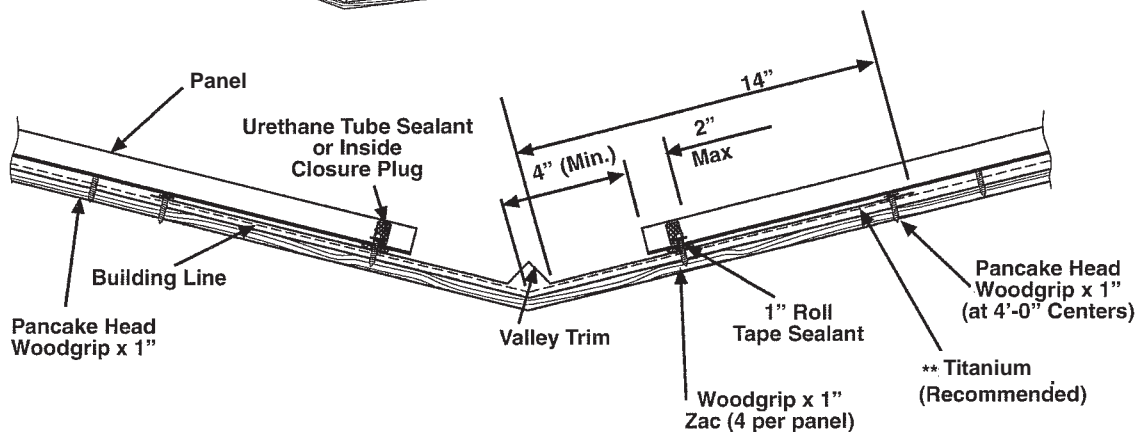

Figure #10

1. Place another layer of 36" roof felt on valley centerline with 18" of paper on each side of center.
2. Begin placing valley trim at eave with a 1" overhang.
3. Caulk and lap the sequential valley trims a minimum of 6".
4. Parallel to the valley, place tape sealant 6" from valley center as shown.
5. Field cut the panels allowing for overlap with valley trim.
 - a. Make cuts through male/female rib (depending on side) at the angle required for the specific roof slope. See Figure #9.
 - b. Cut out shaded or marked area with sheet metal shears. See Figure #10.
6. After panels are field cut and attached, fasten along bottom end using four (4) #10x1" Woodgrips per panel. Make sure fasteners are evenly spaced and penetrate the row of tape sealant.
7. Seal panel end with tube caulking or inside closure plug.

** Additional ice and water shields may be required if climate is extreme.

KBS Metal Roofing

TYPICAL CONDITIONS

High Side Trim Details - Exposed Fastened

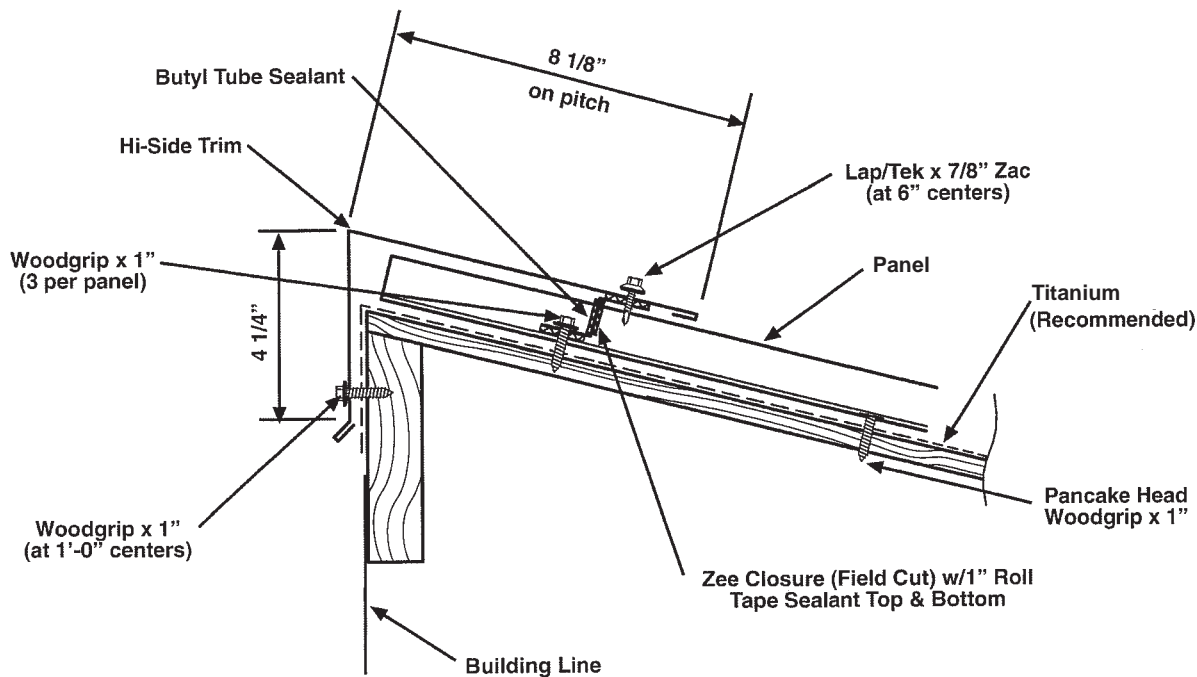
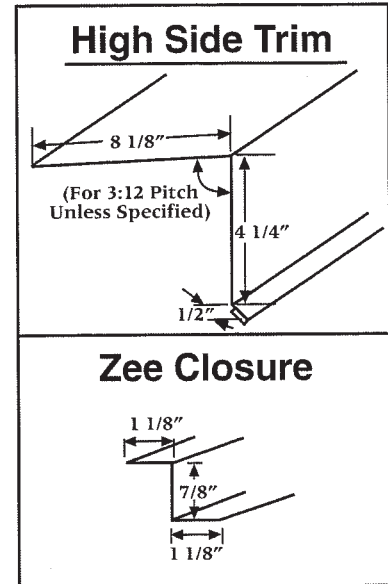
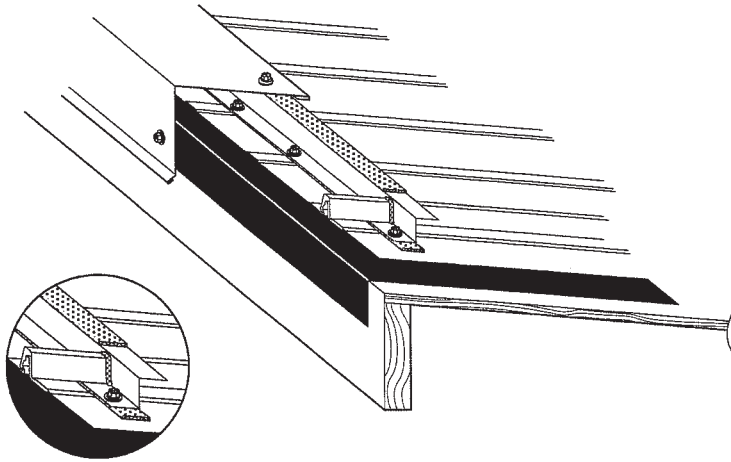

1. Panels should end parallel to high-side.
2. Attach zee closure parallel to high-side.
3. Fasten high-side trim to the zee closure using #14 x 7/8" Lap/Tek Zac at 6" centers.
4. Caulk, lap and fasten the subsequent trims.
5. Fasten the backside of peak trim with #10x1" painted Zac Woodgrips at 12" centers.

Rake Tie-In Trim Details - Exposed Fastened

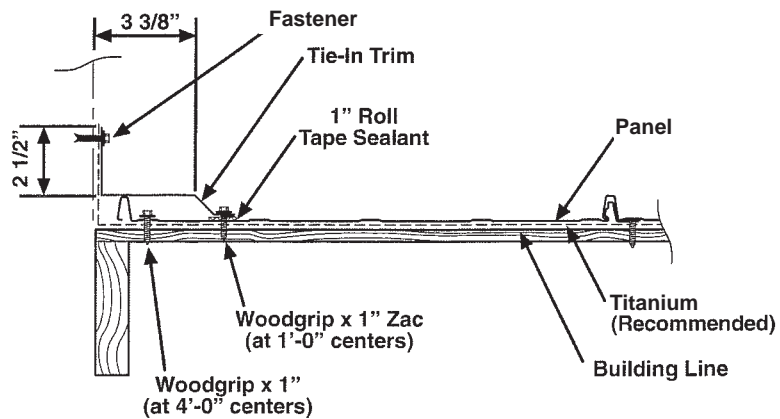
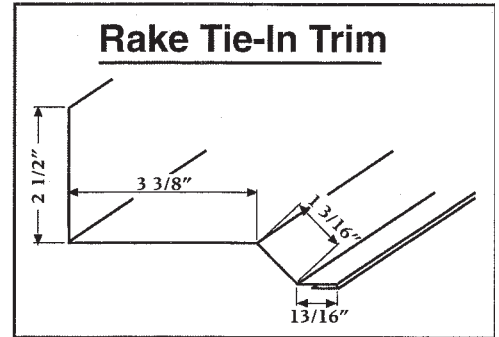
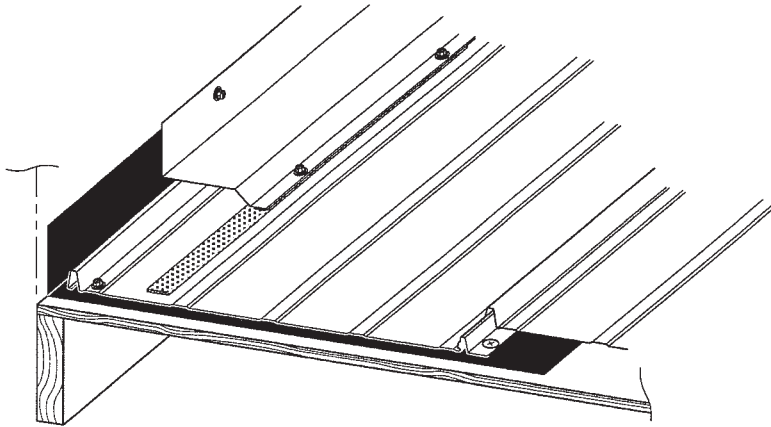

1. Place tape sealant along the endwall tie-in trim's flange.
2. Install endwall tie-in trim. Fasten using painted #10x1" Woodgrip at 12" o.c.
3. Caulk and lap the endwall tie-in trim at least 3" hooking the hem.
4. Cut and fold the endwall tie-in trim at the eave to seal the end.
use STST 43D pop rivets to fasten.
5. Endwall tie-in trim details is the same as outlined in #1-4.

KBS Metal Roofing

TYPICAL CONDITIONS

High Side Tie-In Trim Details - Exposed Fastened

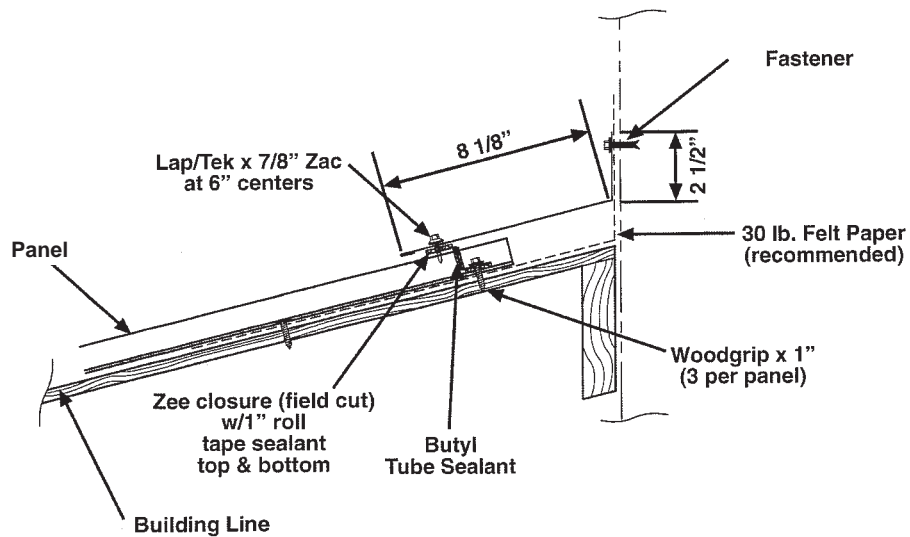
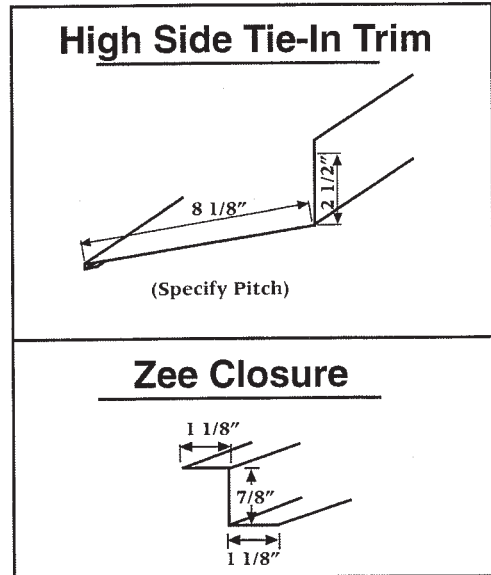
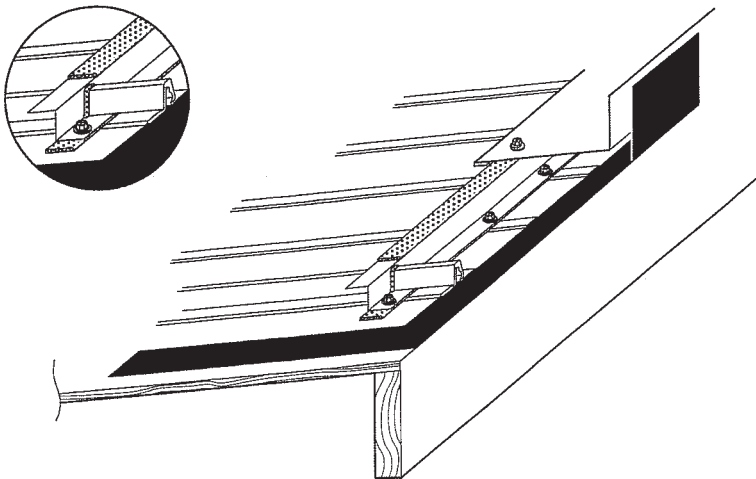

1. Panels should end parallel to the high-side.
2. Attach zee closure parallel to high-side.
3. Fasten sidewall tie-in trim to the zee closure.
4. Caulk, lap and fasten the subsequent trims.

Eave Trim Details - Architectural

Note: Eave trim and offset cleat must be installed prior to panel installation.

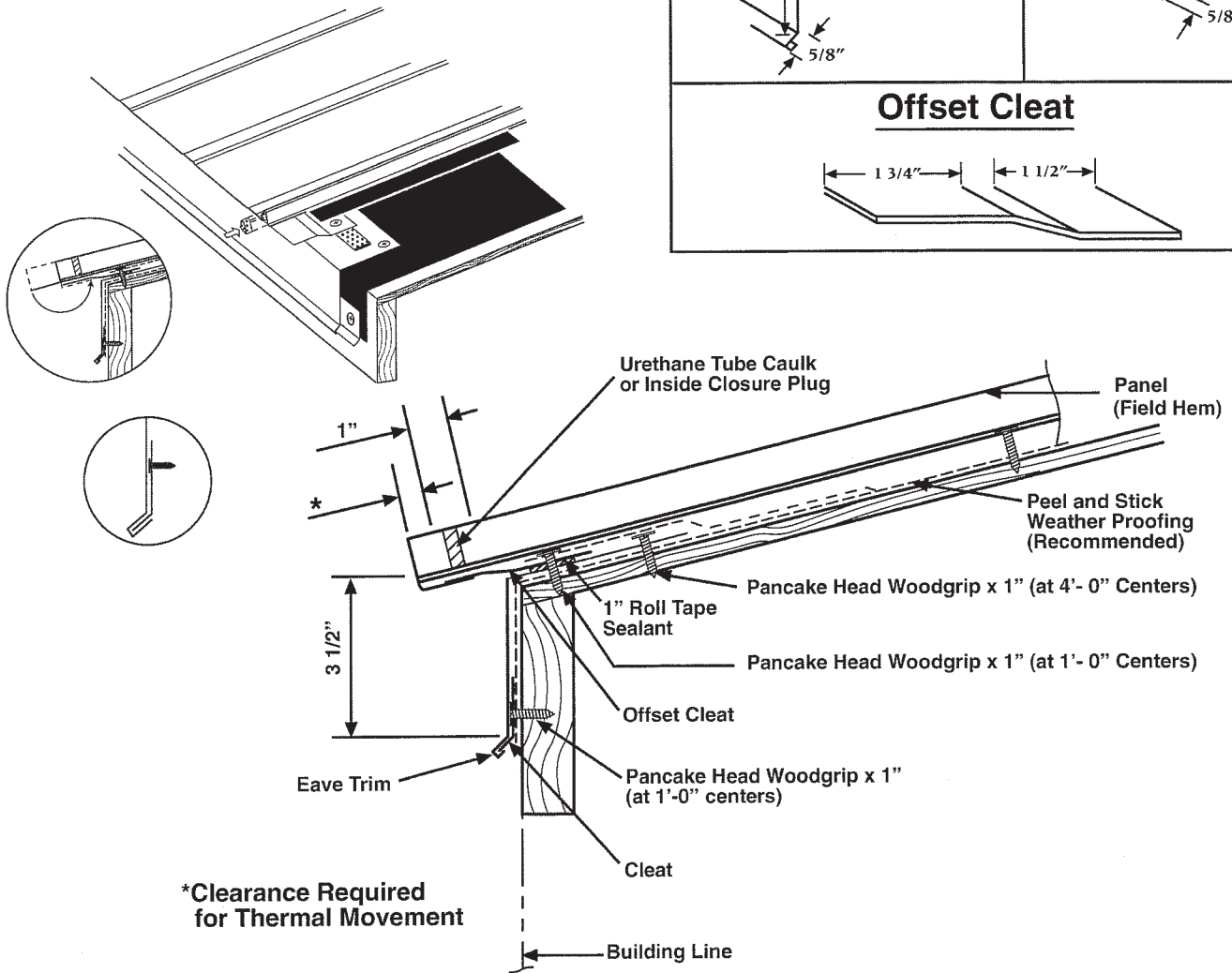
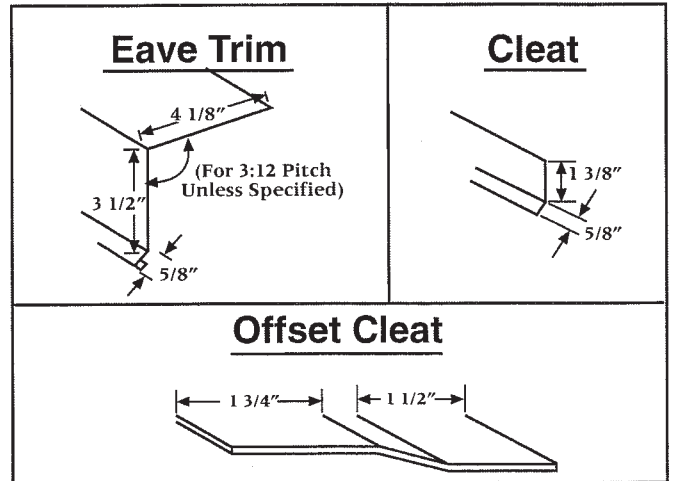

1. Attach cleat as shown with #10 x 1" Pancake Head Fastener.
2. Install eave trim and attach with #10 x 1" Pancake Head Fastener.
3. Place tape sealant on eave trim and attach offset cleat with #10 x 1" Pancake Head Fasteners.

* For field hem panel see page #14

KBS Metal Roofing

TYPICAL CONDITIONS

Rake Trim Details - Architectural

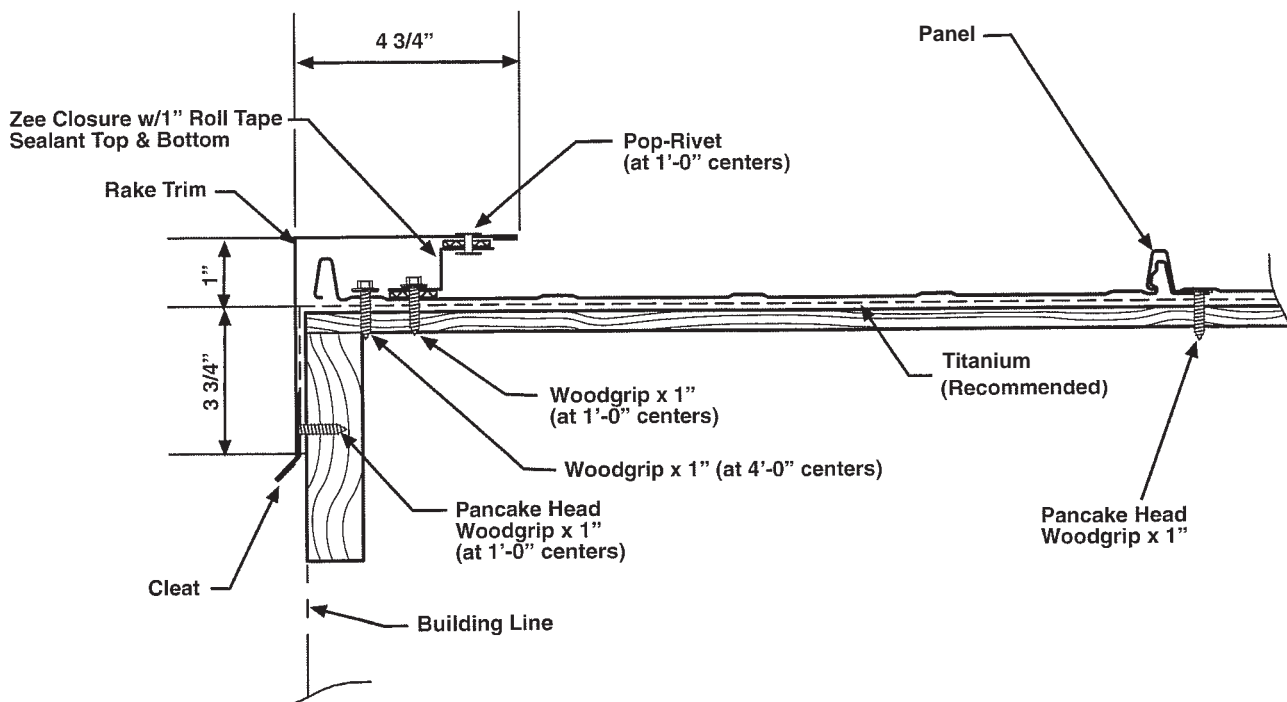
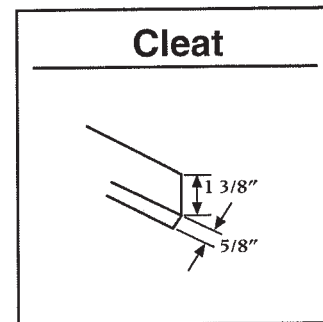
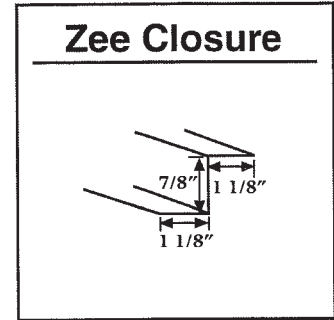
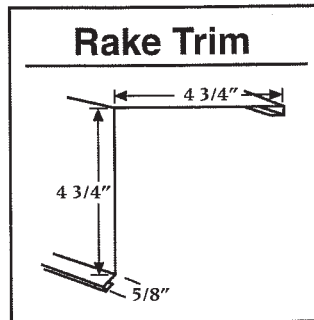
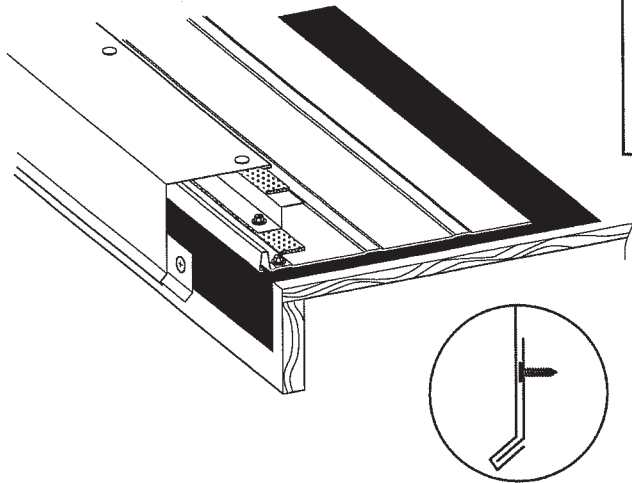

1. Place roof panel per instructions on page #12.
2. Attach cleat as shown with #10 x 1" Pancake Head Fastener.
3. Place tape sealant on panel and attach zee closure with #10 x 1" Woodgrips.
4. Place tape sealant on zee closure, then install rake trim and attach with pop-rivets.

Hip and Ridge Trim Details - Architectural

Note: Rake trim must be installed prior to installing ridge.
Panels must be field cut at hip.

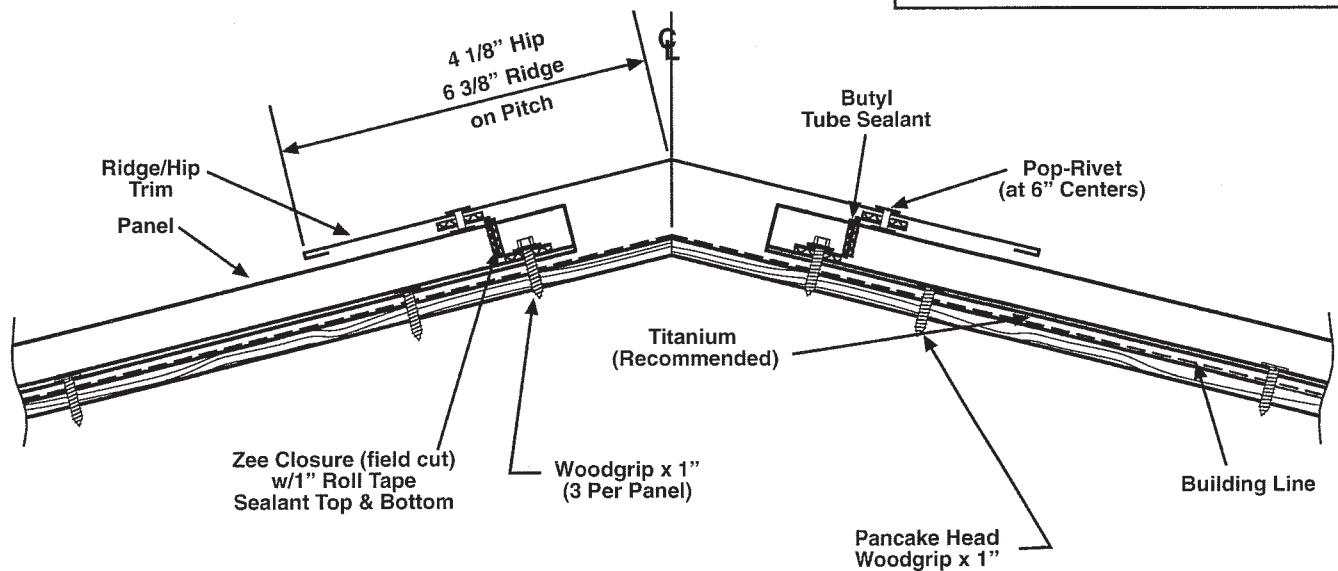
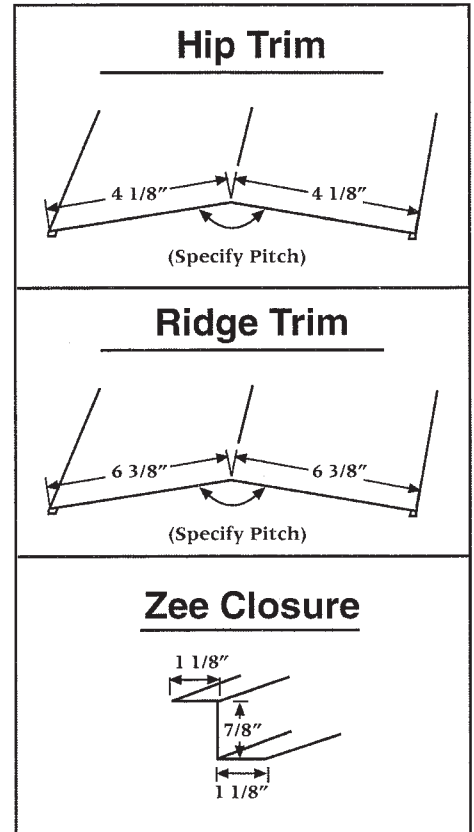
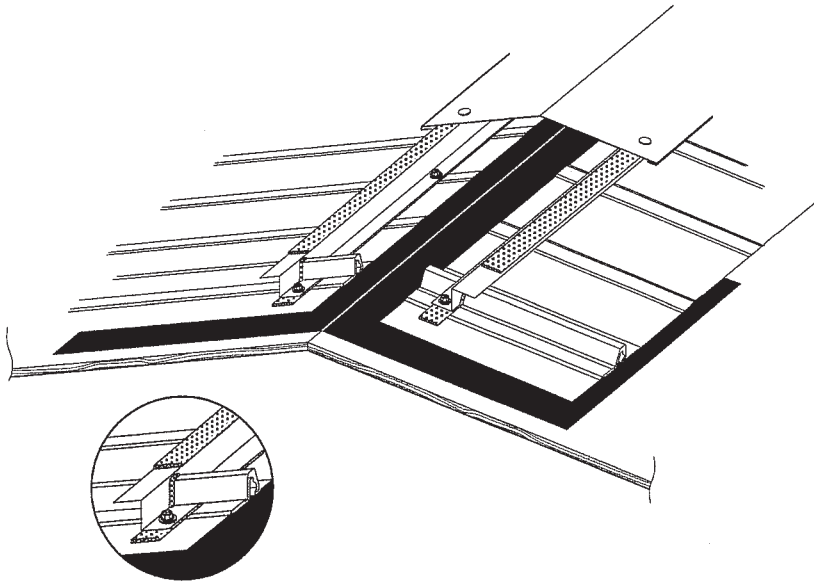

1. Panels should end parallel to ridge.
2. Place tape sealant on panel and attach zee closure parallel to ridge with woodgrip fasteners.
3. Place tape sealant on zee closure and attach hip/ridge trim with pop-rivets.

KBS Metal Roofing

TYPICAL CONDITIONS

Valley Trim Details - Architectural

Note: Valley trim must be installed prior to panel installation. Panels must be field cut at valley.

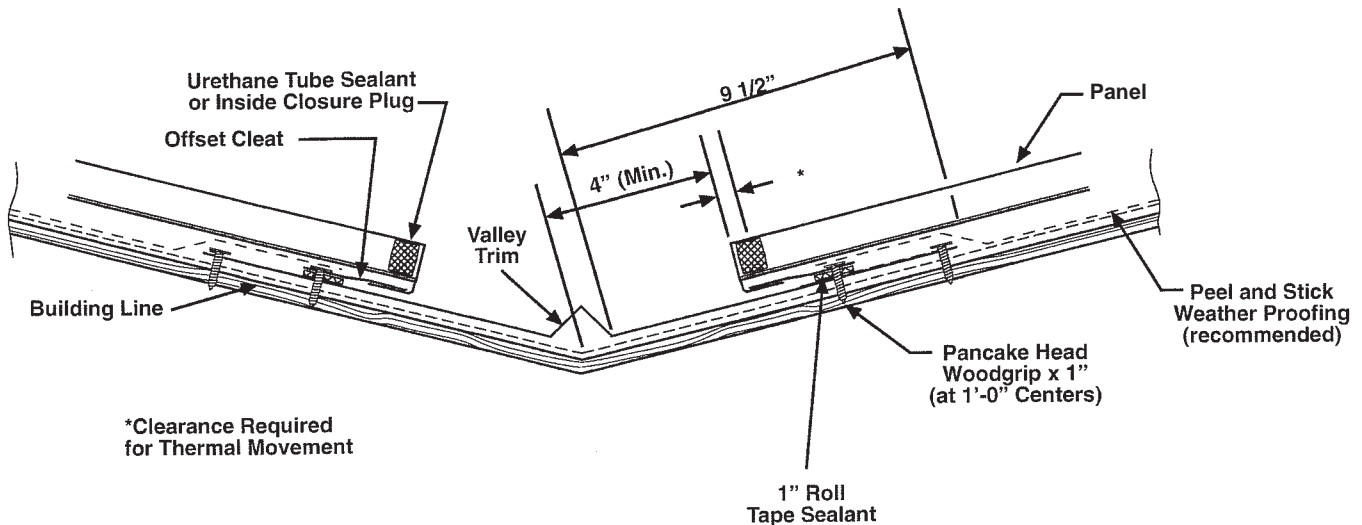
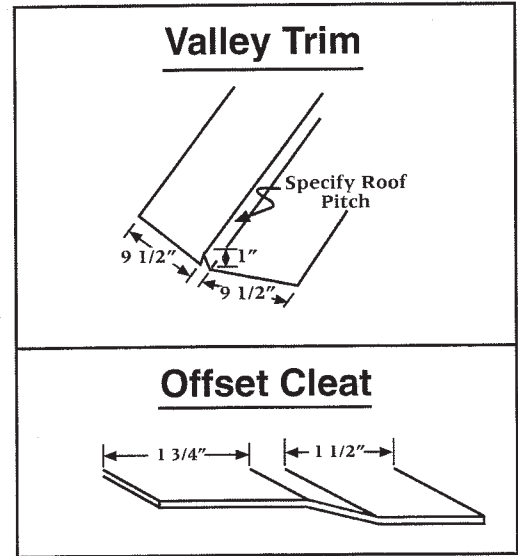
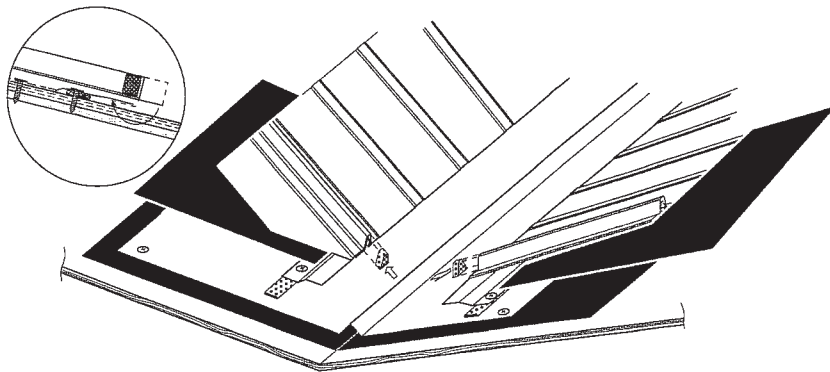

1. Place another layer of 36" roof felt on valley centerline with 18" of paper on each side of center.
2. Begin placing valley trim at eave with a 1" overhang.
3. Caulk and lap the sequential valley trims a minimum of 6".
4. Place tape sealant on valley trim parallel to valley and attach offset cleat with pancake head woodgrip.
5. For field hem panel see page #14.
6. Field cut the panels allowing for overlap with offset cleat and hem see page 14.
 - a. Make cuts through male/female rib (depending on side) at the angle required for the specific roof slope. See Figure #9.
 - b. Cut out shaded or marked area with sheet metal shears. See Figure #10.
7. Seal panel end with tube caulking or inside closure plug.

High Side Trim Details - Architectural

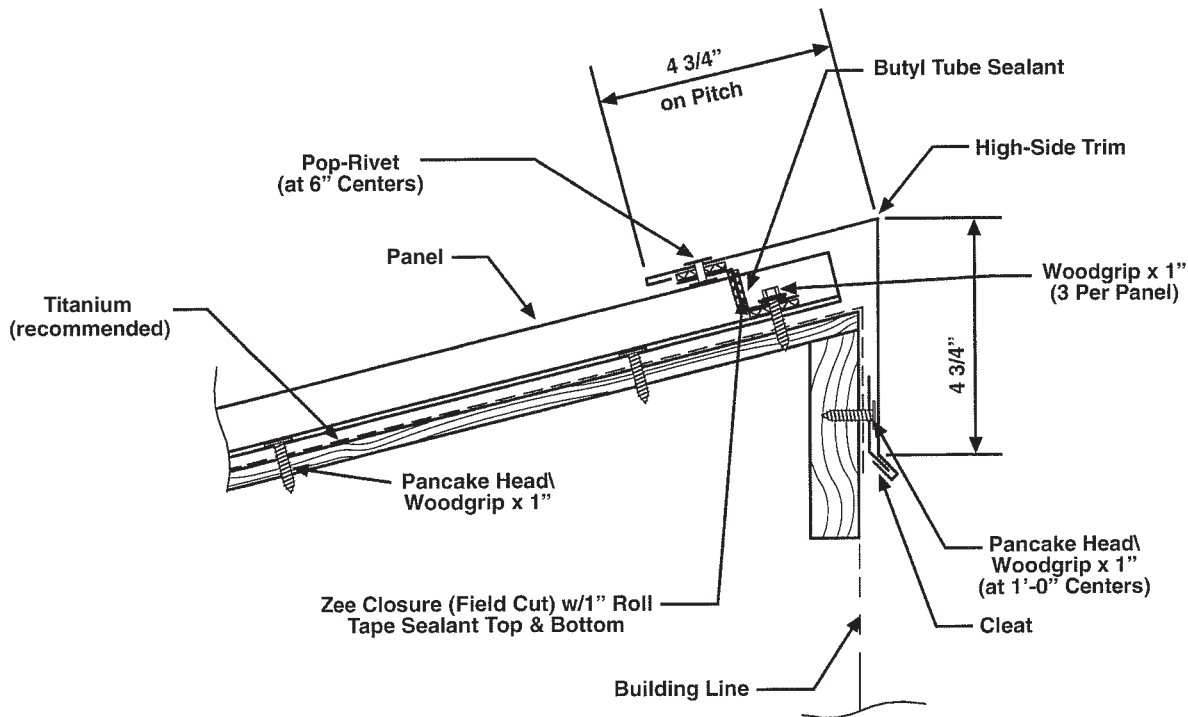
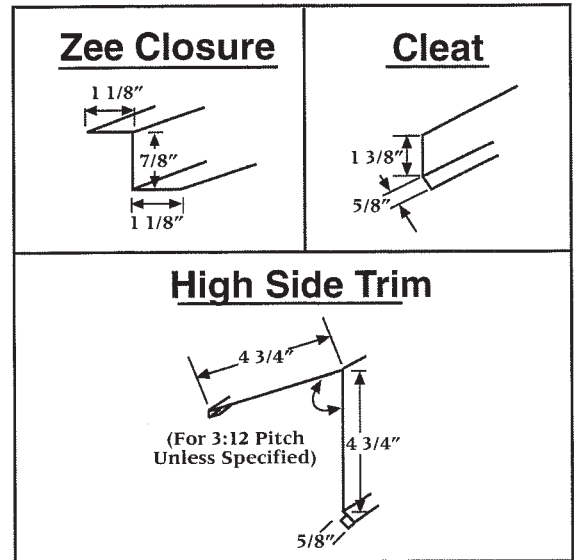
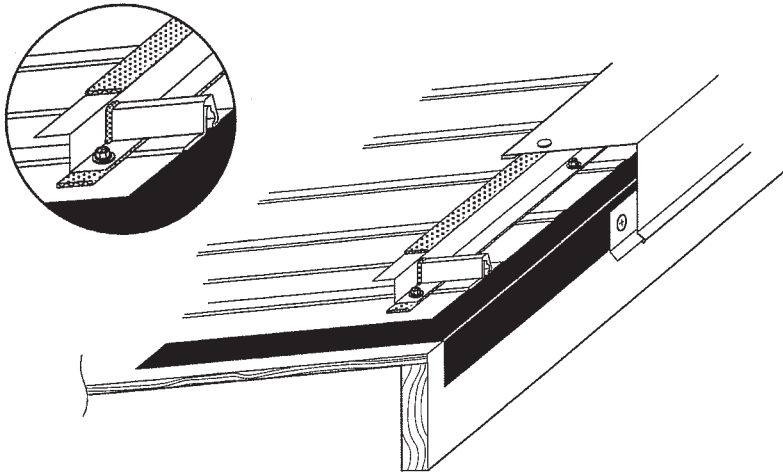

1. Panels should end parallel to peak.
2. Attach cleat as shown with #10 x 1" Pancake Head Woodgrip.
3. Place tape sealant on panel parallel to peak and attach zee closure with (3) 1" woodgrips.
4. Place tape sealant on zee closure and seal panel seam with tube sealant.
5. Install high-side trim with pop-rivets.

KBS Metal Roofing

TYPICAL CONDITIONS

Rake Tie-In Trim Details - Architectural

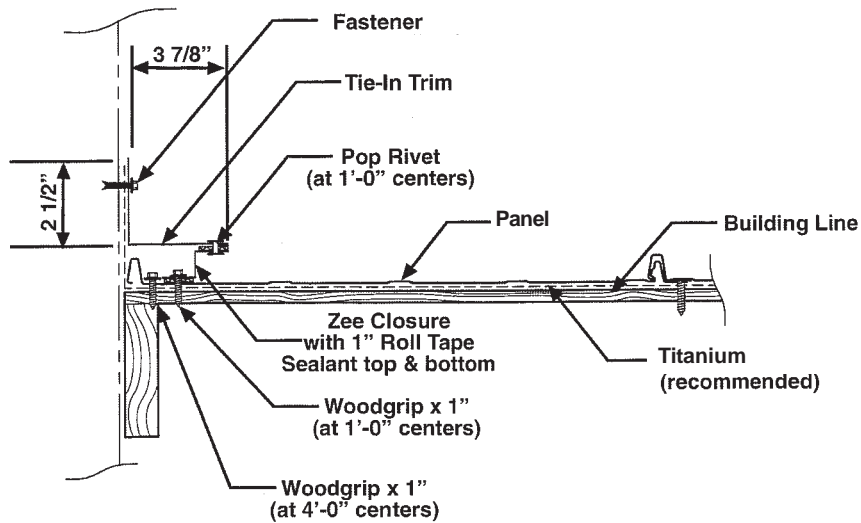
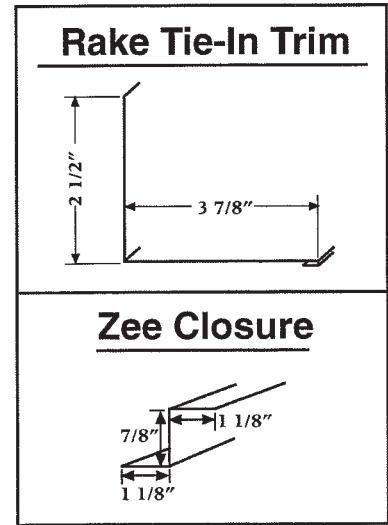
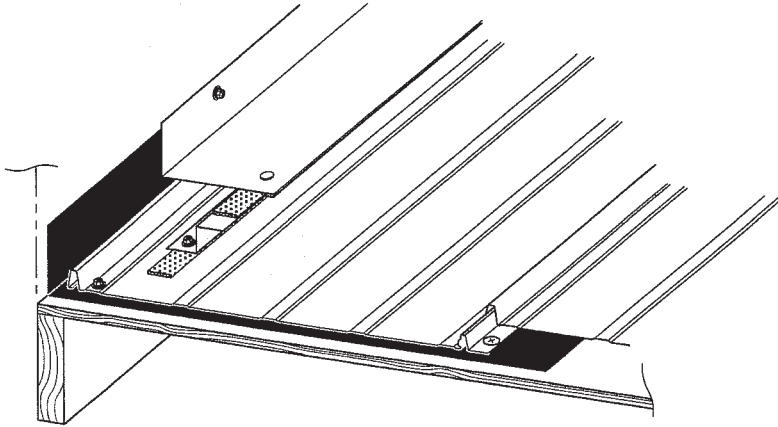

1. Place tape sealant on panel and attach zee closure with #10x1" Woodgrips.
2. Place tape sealant on zee closure, then install endwall tie-in trim.
3. Caulk, lap and fasten the subsequent trims.

High Side Tie-In Trim Details - Architectural

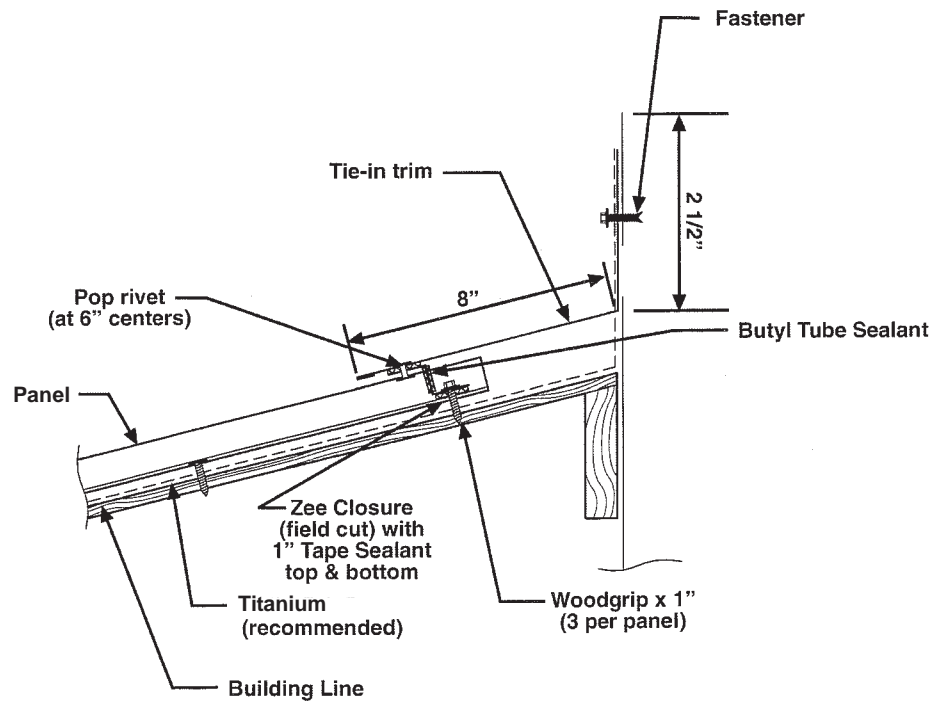
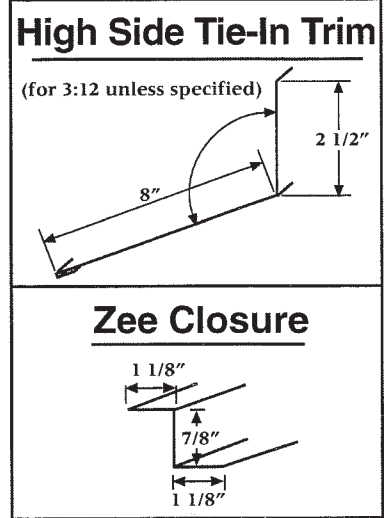
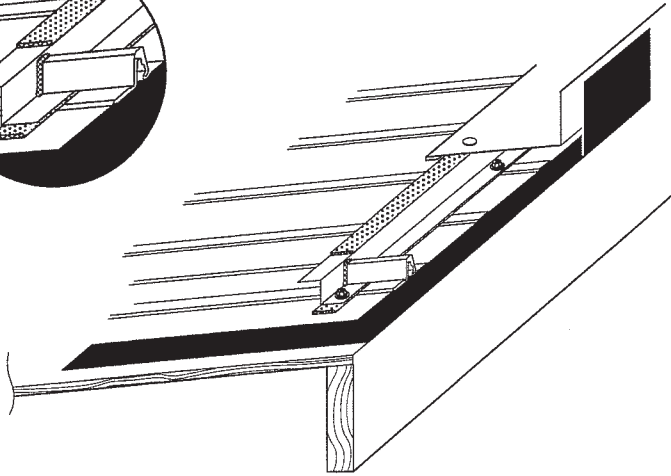
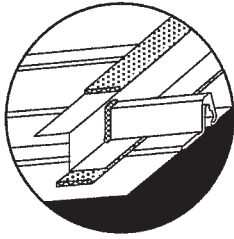

1. Attach zee closure parallel to the high-side.
2. Fasten sidewall tie-in trim to the zee closure.
3. Caulk, lap and fasten the subsequent trim.

KBS Metal Roofing

TYPICAL CONDITIONS

Vent Trim Details

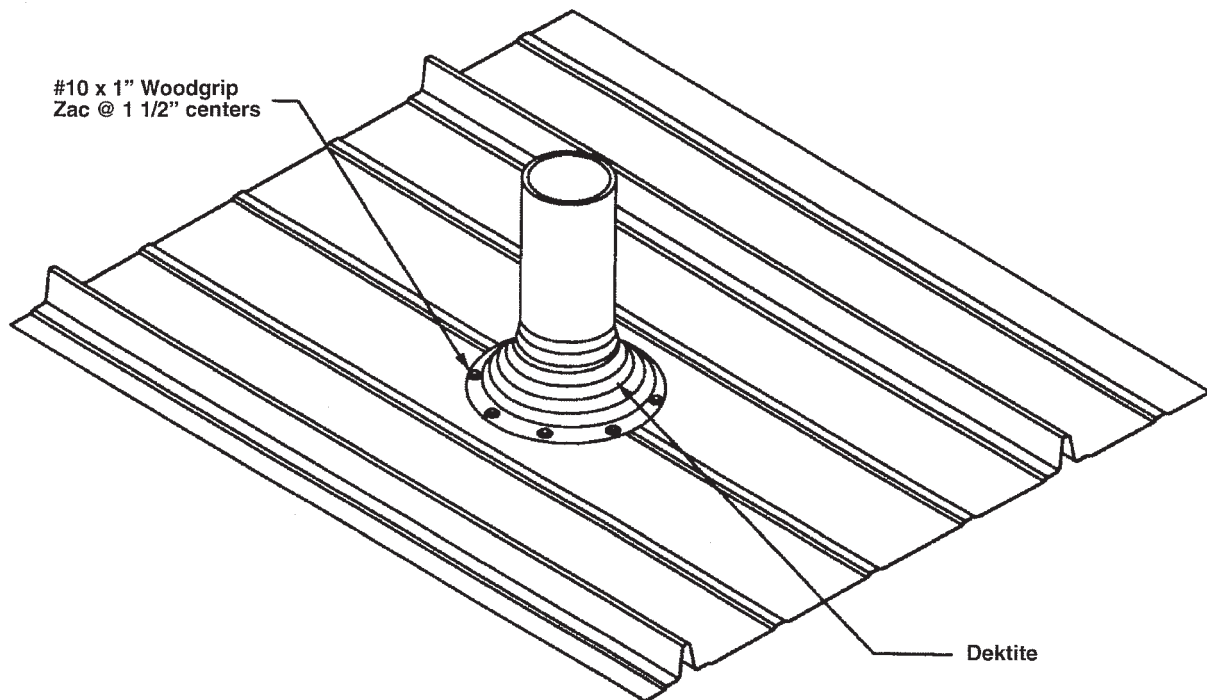

1. Cut pliable dektite at appropriate pipe diameter marking on sleeve.
2. Slide the Dektite boot down over pipe.
3. Seal between base and roof with tube caulk.
4. Adjust base to fit profile of the roof.
5. Fasten the Dektite with #14 x 7/8" Lap Zac at 2" centers.